

Base-Ported Pressure Filter

KC50

Patent No. 6,843,378 for filter cap seal.



Features and Benefits

- Base-ported high pressure filter
- Patented dirt-tolerant cap design
- Can be installed in vertical or horizontal position
- Meets HF4 automotive standard
- Element changeout from top minimizes oil spillage
- Offered in pipe, SAE straight thread, flanged and ISO 228 porting
- No-Element indicator option available
- Available with non-bypass option with high collapse element
- Integral inlet and outlet female test points option available
- Offered in conventional subplate porting
- Double and triple stacking of K-size elements can be replaced by single KK or 27K-size elements

Model No. of filter in photograph is KC501KZ10PD.

100/150 gpm NF30
380/570 L/min NFS30

5000 psi YF30
345 bar DF40

CF40

CFX30

RF60

RFS50

CF60

VF60

KF30

TF50

KF50

KC50

KFH50

MKF50

KC65

Applications



INDUSTRIAL



MINING TECHNOLOGY



POWER GENERATION



STEEL MAKING



PAPER INDUSTRY



AGRICULTURE



MOBILE VEHICLES

Flow Rating:	Up to 100 gpm (380 L/min) for 150 SUS (32 cSt) fluids With 2" porting only, up to 150 gpm (570 L/min) for 150 SUS (32 cSt) fluids
Max. Operating Pressure:	5000 psi (345 bar)
Min. Yield Pressure:	15,000 psi (1035 bar)
Rated Fatigue Pressure:	3500 psi (240 bar), per NFPA T2.6.1-2005
Temp. Range:	-20°F to 225°F (-29°C to 107°C)
Bypass Setting:	Cracking: 40 psi (2.8 bar) Optional Cracking: 50 psi (3.5 bar) Full Flow: 61 psi (4.2 bar) Non-bypassing model has a blocked bypass.
Porting Base & Cap:	Ductile Iron
Element Case:	Steel
Weight of KC50-1K:	66.8 lbs. (30.3 kg)
Weight of KC50-2K:	87.8 lbs. (39.8 kg)
Weight of KC50-3K:	109.6 lbs. (49.7 kg)
Element Change Clearance:	8.50" (215 mm) for 1K; 17.50" (445 mm) for KK; 26.5" (673 mm) for 27K

Filter Housing Specifications

FOF60-03

NOF30-05

NOF50-760

NMF30

RMF60

Cartridge Elements

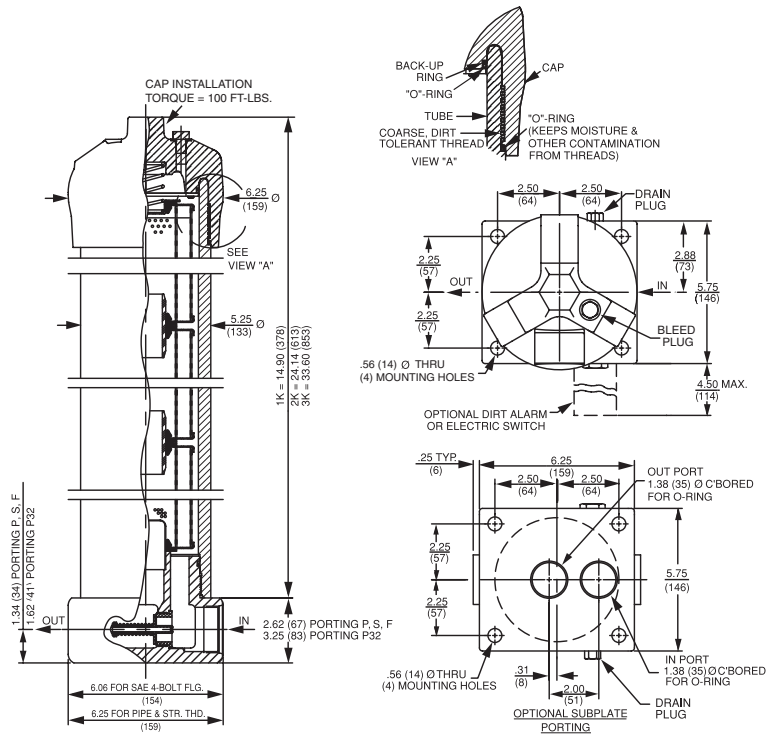

Metric dimensions in ().

Element Performance Information

Element	Filtration Ratio Per ISO 4572/NFPA T3.10.8.8 Using automated particle counter (APC) calibrated per ISO 4402			Filtration Ratio wrt ISO 16889 Using APC calibrated per ISO 11171	
	$\beta_x \geq 75$	$\beta_x \geq 100$	$\beta_x \geq 200$	$\beta_{x(c)} \geq 200$	$\beta_{x(c)} \geq 1000$
K3/KK3/27K3	6.8	7.5	10.0	N/A	N/A
K10/KK10/27K10	15.5	16.2	18.0	N/A	N/A
KZ1/KKZ1/27KZ1	<1.0	<1.0	<1.0	<4.0	4.2
KZ3/KKZ3/27KZ3	<1.0	<1.0	<2.0	<4.0	4.8
KZ5/KKZ5/27KZ5	2.5	3.0	4.0	4.8	6.3
KZ10/KKZ10/27KZ10	7.4	8.2	10.0	8.0	10.0
KZ25/KKZ25/27KZ25	18.0	20.0	22.5	19.0	24.0
KZX3/KKZX3/27KZX3	<1.0	<1.0	<2.0	4.7	5.8
KZX10/KKZX10/27KZX10	7.4	8.2	10.0	8.0	9.8

Dirt Holding Capacity

Element	DHC (gm)	Element	DHC (gm)	Element	DHC (gm)
K3	54	KK3	108	27K3	162
K10	44	KK10	88	27K10	132
KZ1	112	KKZ1	224	27KZ1	336
KZ3	115	KKZ3	230	27KZ3	345
KZ5	119	KKZ5	238	27KZ5	357
KZ10	108	KKZ10	216	27KZ10	324
KZ25	93	KKZ25	186	27KZ25	279
KZX3	40*	KKZX3	80	27KZX3	120
KZX10	49*	KKZX10	98	27KZX10	147

*Based on 100 psi terminal pressure

Element Collapse Rating: 150 psid (10 bar) for standard elements
3000 psid (210 bar) for high collapse (ZX) versions

Flow Direction: Outside In

Element Nominal Dimensions: K: 3.9" (99 mm) O.D. x 9.0" (230 mm) long
KK: 3.9" (99 mm) O.D. x 18.0" (460 mm) long
27K: 3.9" (99 mm) O.D. x 27.0" (690 mm) long

Base-Ported Pressure Filter **KC50**

Type Fluid Appropriate Schroeder Media

Petroleum Based Fluids	All E (cellulose) and Z (synthetic) media
High Water Content	All Z (synthetic) media
Invert Emulsions	10 and 25 μ Z (synthetic) media
Water Glycols	3, 5, 10 and 25 μ Z (synthetic) media
Phosphate Esters	All Z (synthetic) media with H (EPR) seal designation and 3 and 10 μ E (cellulose) with H (EPR) seal designation
Skydrol®	3, 5, 10 and 25 μ Z (synthetic) media with H.5 seal designation and W (water removal) media with H.5 seal designation (EPR seals and stainless steel wire mesh in element, and light oil coating on housing exterior)

Fluid Compatibility

- NF30
- NFS30
- YF30
- DF40
- CF40
- CFX30
- RF60
- RF550
- CF60
- VF60
- KF30
- TF50
- KF50
- KFH50
- MKF50
- KC65
- FOF60-03
- NOF30-05
- NOF50-760
- NMF30
- RMF60
- Cartridge Elements

Skydrol is a registered trademark of Solutia Inc.

Element Selection Based on Flow Rate

Element selections are predicated on the use of 150 SUS (32 cSt) petroleum based fluid and a 40 psi (2.8 bar) bypass valve.

Pressure	Element Series	Element Part No.	Element Selections					
			1K3	2K3†	3K3	See MKF50		
To 5000 psi (345 bar)	E Media	K10	1K10	2K10†	3K10†	3K10†	See MKF50	
		K25	1K25			2K25†		
		KZ1	1KZ1	2KZ1†		3KZ1†		
	Z Media	KZ3	1KZ3			2KZ3†	3KZ3†	
		KZ5	1KZ5			2KZ5†	3KZ5†	
		KZ10	1KZ10			2KZ10†	3KZ10†	
		KZ25	1KZ25			2KZ25†		
Flow	gpm	0	25	50	75	100	125	150
		(L/min)	0	100	200	300	400	500

†Double and triple stacking of K-size elements can be replaced by single KK & 27K elements, respectively. requires 2" porting (P32)

Shown above are the elements most commonly used in this housing.

Note: Contact factory regarding use of E Media in High Water Content, Invert Emulsion and Water Glycol Applications. For more information, refer to Fluid Compatibility: Fire Resistant Fluids, pages 19 and 20.

ΔP_{housing}

KC50 ΔP_{housing} for fluids with sp gr = 0.86:

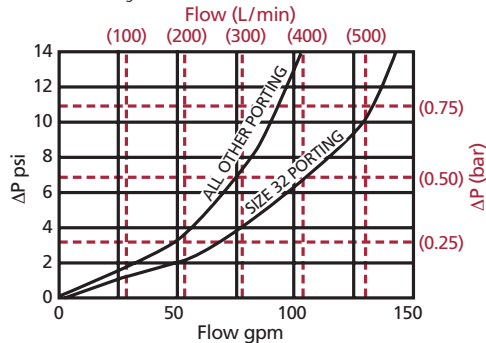

sp gr = specific gravity

Sizing of elements should be based on element flow information provided in the Element Selection chart above.

ΔP_{element}

ΔP_{element} = flow x element ΔP factor x viscosity factor

El. ΔP factors @ 150 SUS (32 cSt):

	1K	2K	3K
K3	.25	.12	.08
K10	.09	.05	.03
K25	.02	.01	.01
KZ1	.20	.10	.05
KZ3	.10	.05	.03
KZ5	.08	.04	.02
KZ10	.05	.03	.02
KZ25	.04	.02	.01
KZX10	.22	.11	.07

If working in units of bars & L/min, divide above factor by 54.9.

Viscosity factor: Divide viscosity by 150 SUS (32 cSt).

Pressure Drop Information

Based on Flow Rate and Viscosity

KC50

KFH50

MKF50

KC65

FOF60-03

NOF30-05

NOF50-760

NMF30

RMF60

Cartridge Elements

Notes

$$\Delta P_{\text{filter}} = \Delta P_{\text{housing}} + \Delta P_{\text{element}}$$

Exercise:

Determine ΔP at 50 gpm (190 L/min) for KC501KZ3PD5 using 200 SUS (44 cSt) fluid.

Solution:

$$\Delta P_{\text{housing}} = 3.0 \text{ psi } [.20 \text{ bar}]$$

$$\begin{aligned} \Delta P_{\text{element}} &= 50 \times .10 \times (200 \div 150) = 6.7 \text{ psi} \\ &\text{or} \\ &= [190 \times (.10 \div 54.9) \times (44 \div 32) = .48 \text{ bar}] \end{aligned}$$

$$\begin{aligned} \Delta P_{\text{total}} &= 3.0 + 6.7 = 9.7 \text{ psi} \\ &\text{or} \\ &= [.20 + .48 = .68 \text{ bar}] \end{aligned}$$

Filter Model Number Selection

How to Build a Valid Model Number for a Schroeder KC50:

BOX 1	BOX 2	BOX 3	BOX 4	BOX 5	BOX 6	BOX 7	BOX 8
KC50	-	-	-	-	-	-	-

Example: NOTE: Only boxes 6 and 8 may contain more than one option

BOX 1	BOX 2	BOX 3	BOX 4	BOX 5	BOX 6	BOX 7	BOX 8
KC50	1	KZ5	-	S	-	D5	-

= KC501KZ5SD5

Filter Series	Number of Elements	Element Part Number					
KC50 (See Section 5 for Water Service version)	1	K	KK	27K			
	2	K3	KK3	27K3	= 3 μ E media (cellulose)		
	3	K10	KK10	27K10	= 10 μ E media (cellulose)		
KCN50 (Non-bypassing; requires ZX high collapse elements)		K25			= 25 μ E media (cellulose)		
		KZ1	KKZ1	27KZ1	= 1 μ Excellement® Z media (synthetic)		
		KZ3	KKZ3	27KZ3	= 3 μ Excellement Z media (synthetic)		
		KZ5	KKZ5	27KZ5	= 5 μ Excellement Z media (synthetic)		
		KZ10	KKZ10	27KZ10	= 10 μ Excellement Z media (synthetic)		
		KZ25	KKZ25	27KZ25	= 25 μ Excellement Z media (synthetic)		
		KZX1	KKZX1	27KZX1	= 1 μ Excellement Z media (high collapse center tube)		
		KZX3	KKZX3	27KZX3	= 3 μ Excellement Z media (high collapse center tube)		
		KZX5	KKZX5	27KZX5	= 5 μ Excellement Z media (high collapse center tube)		
		KZX10	KKZX10	27KZX10	= 10 μ Excellement Z media (high collapse center tube)		
		KZX25	KKZX25	27KZX25	= 25 μ Excellement Z media (high collapse center tube)		
		KW	KKW	27KW	= W media (water removal)		
		KM10			= K size 10 μ M media (reusable metal)		
		KM25			= K size 25 μ M media (reusable metal)		
		KM60			= K size 60 μ M media (reusable metal)		
	KM150			= K size 150 μ M media (reusable metal)			
	KM260			= K size 260 μ M media (reusable metal)			

BOX 4	BOX 5	BOX 6	BOX 7
Seal Material Omit = Buna N V = Viton® H = EPR H.5 = Skydrol® compatibility	Porting P = 1½" NPTF P32 = 2" NPTF S = SAE-24 F = 1½" SAE 4-bolt flange Code 62 O = Subplate B = ISO 228 G-1½"	Options Omit = None M = Magnet inserts (not available w/ indicator in cap) X = Blocked bypass 50 = 50 psi bypass setting L = Two ¼" NPTF inlet and outlet female test ports U = Series 1215 7/16 UNF Schroeder Check® Test Point installation in cap (upstream) UU = Series 1215 7/16 UNF Schroeder Check Test Point installation in base (upstream and downstream)	Dirt Alarm® Options Omit = None Visual D = Pointer D5 = Visual pop-up D5C = D5 in cap D9 = All stainless D5 Visual with Thermal Lockout D8 = Visual w/ thermal lockout D8C = D8 in cap Electrical MS5 = Electrical w/ 12 in. 18 gauge 4-conductor cable MS5LC = Low current MS5 MS10 = Electrical w/ DIN connector (male end only) MS10LC = Low current MS10 MS11 = Electrical w/ 12 ft. 4-conductor wire MS12 = Electrical w/ 5 pin Brad Harrison connector (male end only) MS12LC = Low current MS12 MS16 = Electrical w/ weather-packed sealed connector MS16LC = Low current MS16 MS17LC = Electrical w/ 4 pin Brad Harrison male connector Electrical with Thermal Lockout MS5T = MS5 (see above) w/ thermal lockout MS5LC T = Low current MS5T MS10T = MS10 (see above) w/ thermal lockout MS10LC T = Low current MS10T MS12T = MS12 (see above) w/ thermal lockout MS12LC T = Low current MS12T MS16T = MS16 (see above) w/ thermal lockout MS16LC T = Low current MS16T MS17LC T = Low current MS17T Electrical Visual MS = Cam operated switch w/ ½" conduit female connection MS13 = Supplied w/ threaded connector & light MS14 = Supplied w/ 5 pin Brad Harrison connector & light (male end) Electrical Visual with Thermal Lockout MS13DCT = MS13 (see above), direct current, w/ thermal lockout MS13DCLCT = Low current MS13DCT MS14DCT = MS14 (see above), direct current, w/ thermal lockout MS14DCLCT = Low current MS14DCT
BOX 8 Additional Options Omit = None N = No-Element indicator G509 = Dirt alarm and drain opposite standard G588 = Electrical switch and drain opposite standard			

NOTES:

- Box 2. Number of elements must equal 1 when using KK or 27K elements.
- Box 3. Replacement element part numbers are identical to contents of Boxes 3 and 4. Double and triple stacking of K-size elements can be replaced by single KK and 27K elements, respectively.
- Box 4. H.5 seal designation includes the following: EPR seals, stainless steel wire mesh on elements, and light oil coating on housing exterior. Viton is a registered trademark of DuPont Dow Elastomers. Skydrol is a registered trademark of Solutia Inc.
- Box 5. For option F, bolt depth .75" (19 mm). For option O, O-rings included; hardware not included.
- Box 6. X and 50 options are not available with KCN50.
- Box 7. Standard indicator setting for non-bypassing model is 50 psi unless otherwise specified.
- Box 8. Options N, G509 and G588 are not available with KCN50. N option should be used in conjunction with dirt alarm.