

Manifold Mounted Pressure Filter **NFS30**



Features and Benefits

- Manifold mounted pressure filter
- Offered in square head conventional subplate porting
- Direct mounting to inlet port on customer's manifold

Model No. of filter in photograph is NFS301NZ3OD5.

20 gpm
75 L/min
3000 psi
210 bar

NF30

NFS30

YF30

DF40

CF40

CFX30

RF60

RFS50

CF60

VF60

KF30

TF50

KF50

KC50

KFH50

MKF50

KC65

FOF60-03

NOF30-05

NOF50-760

NMF30

RMF60

Cartridge
Elements

Applications



INDUSTRIAL



AUTOMOTIVE
MANUFACTURING



MACHINE
TOOL



STEEL
MAKING



OFFSHORE



MARINE



PAPER
INDUSTRY



AGRICULTURE



MOBILE
VEHICLES

Flow Rating:	Up to 20 gpm (75 L/min) for 150 SUS (32 cSt) fluids
Max. Operating Pressure:	3000 psi (210 bar)
Min. Yield Pressure:	10,000 psi (690 bar)
Rated Fatigue Pressure:	2400 psi (165 bar)
Temp. Range:	-20°F to 225°F (-29°C to 107°C)
Bypass Setting:	Cracking: 40 psi (2.8 bar) Full Flow: 85 psi (5.9 bar)
Porting Head:	Aluminum
Element Case:	Aluminum
Weight of NFS30-1N:	3.6 lbs. (1.6 kg)
Weight of NFS30-1NN:	4.3 lbs. (2.0 kg)
Element Change Clearance:	4.50" (115 mm)

Filter Housing Specifications

NFS30 WITH "O" PORT CONFIGURATION

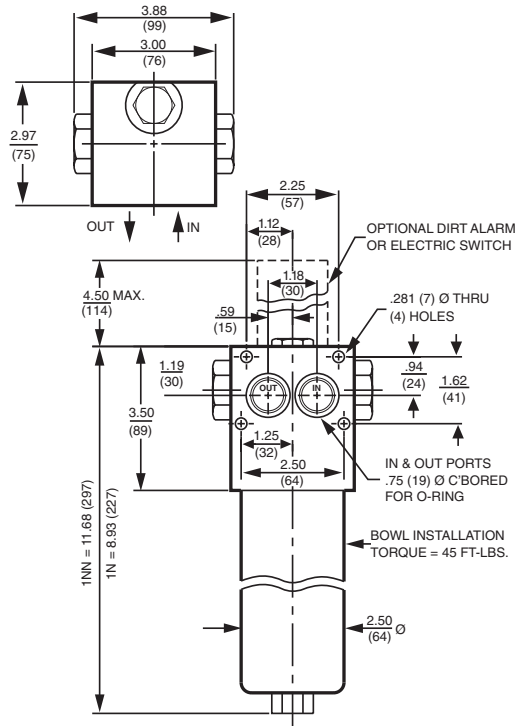

NFS30 WITH PO, SO, FO PORT CONFIGURATION

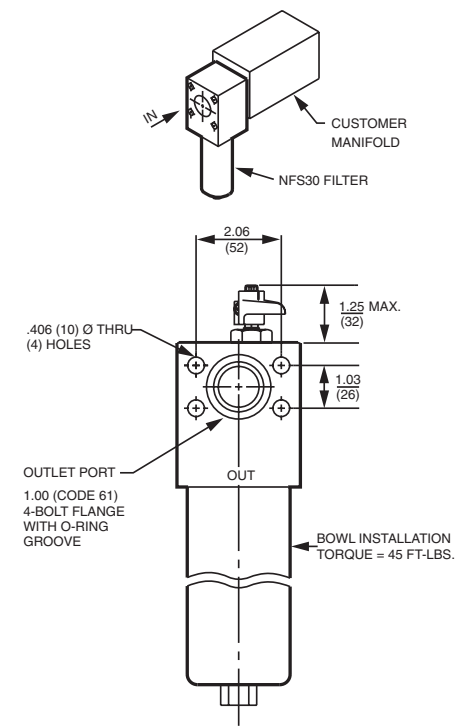

Metric dimensions in ().

Element Performance Information

Element	Filtration Ratio Per ISO 4572/NFPA T3.10.8.8 Using automated particle counter (APC) calibrated per ISO 4402			Filtration Ratio wrt ISO 16889 Using APC calibrated per ISO 11171	
	$\beta_x \geq 75$	$\beta_x \geq 100$	$\beta_x \geq 200$	$\beta_{x(c)} \geq 200$	$\beta_{x(c)} \geq 1000$
N3/NN3	6.8	7.5	10.0	N/A	N/A
N10/NN10	15.5	16.2	18.0	N/A	N/A
NZ1/NNZ1	<1.0	<1.0	<1.0	<4.0	4.2
NZ3/NNZ3	<1.0	<1.0	<2.0	<4.0	4.8
NZ5/NNZ5	2.5	3.0	4.0	4.8	6.3
NZ10/NNZ10	7.4	8.2	10.0	8.0	10.0
NZ25/NNZ25	18.0	20.0	22.5	19.0	24.0

Dirt Holding Capacity

Element	DHC (gm)	Element	DHC (gm)
N3	8	NN3	12
N10	7	NN10	10
NZ1	12	NNZ1	15
NZ3	12	NNZ3	16
NZ5	12	NNZ5	18
NZ10	11	NNZ10	15
NZ25	11	NNZ25	15

Element Collapse Rating: 150 psid (10 bar) for standard elements
3000 psid (210 bar) for high collapse (ZX) versions

Flow Direction: Outside In

Element Nominal Dimensions: N: 1.75" (45 mm) O.D. x 5.25" (135 mm) long
NN: 1.75" (45 mm) O.D. x 8.0" (200 mm) long

Manifold Mounted Pressure Filter **NFS30**

Type Fluid	Appropriate Schroeder Media
Petroleum Based Fluids	All E (cellulose) and Z (synthetic) media
High Water Content	All Z (synthetic) media
Invert Emulsions	10 and 25 μ Z (synthetic) media
Water Glycols	3, 5, 10 and 25 μ Z (synthetic) media

Fluid Compatibility

NF30

NFS30

YF30

DF40

CF40

CFX30

RF60

RFS50

CF60

VF60

KF30

TF50

KF50

KC50

KFH50

MKF50

KC65

FOF60-03

NOF30-05

NOF50-760

NMF30

RMF60

Cartridge Elements

Pressure	Series	Element Part No.	Element selections are predicated on the use of 150 SUS (32 cSt) petroleum based fluid and a 40 psi (2.8 bar) bypass valve.			
To 3000 psi (210 bar)	E Media	N3 & NN3	1N3	1NN3	See DF40	
		N10 & NN10	1N10		1NN10	
		N25 & NN25	1N25 & 1NN25			
	Z Media	NZ1 & NNZ1	1NZ1	1NNZ1	See DF40	
		NZ3 & NNZ3	1NZ3		1NNZ3	
		NZ5 & NNZ5	1NZ5			1NNZ5
		NZ10 & NNZ10	1NZ10 & 1NNZ10			
		NZ25 & NNZ25	1NZ25 & 1NNZ25			
Flow	gpm	0	5	10	15	20
	(L/min)	0	25	50	50	75

Element Selection Based on Flow Rate

Shown above are the elements most commonly used in this housing.

Note: Contact factory regarding use of E Media in High Water Content, Invert Emulsion and Water Glycol Applications. For more information, refer to Fluid Compatibility: Fire Resistant Fluids, pages 19 and 20.

$\Delta P_{\text{housing}}$

NFS30 $\Delta P_{\text{housing}}$ for fluids with sp gr = 0.86:

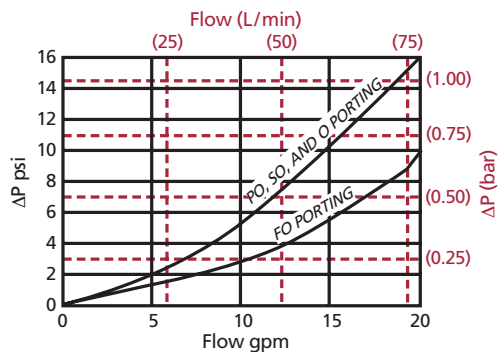

sp gr = specific gravity

Sizing of elements should be based on element flow information provided in the Element Selection chart above.

$\Delta P_{\text{element}}$

$\Delta P_{\text{element}} = \text{flow} \times \text{element } \Delta P \text{ factor} \times \text{viscosity factor}$

El. ΔP factors @ 150 SUS (32 cSt):

	1N	1NN
N3	1.10	NN3 .77
N10	.17	NN10 .13
N25	.10	NN25 .07
NZ1	1.43	NNZ1 1.23
NZ3	.92	NNZ3 .56
NZ5	.71	NNZ5 .46
NZ10	.57	NNZ10 .35
NZ25	.36	NNZ25 .20

If working in units of bars & L/min, divide above factor by 54.9.

Viscosity factor: Divide viscosity by 150 SUS (32 cSt).

Pressure Drop Information

Based on Flow Rate and Viscosity

KC65

Notes

$$\Delta P_{\text{filter}} = \Delta P_{\text{housing}} + \Delta P_{\text{element}}$$

Exercise:

Determine ΔP at 10 gpm (38 L/min) for NFS301NNZ10FOD using 200 SUS (44 cSt) fluid.

Solution:

$$\Delta P_{\text{housing}} = 3.0 \text{ psi } [.25 \text{ bar}]$$

$$\begin{aligned} \Delta P_{\text{element}} &= 10 \times .35 \times (200 \div 150) = 4.7 \text{ psi} \\ &\text{or} \\ &= [38 \times (.35 \div 54.9) \times (44 \div 32)] = .33 \text{ bar} \end{aligned}$$

$$\begin{aligned} \Delta P_{\text{total}} &= 3.0 + 4.7 = 7.7 \text{ psi} \\ &\text{or} \\ &= [.25 + .33 = .58 \text{ bar}] \end{aligned}$$

Filter Model Number Selection

How to Build a Valid Model Number for a Schroeder NFS30:

BOX 1	BOX 2	BOX 3	BOX 4	BOX 5	BOX 6	BOX 7
NFS30						

Example: NOTE: One option per box

BOX 1	BOX 2	BOX 3	BOX 4	BOX 5	BOX 6	BOX 7
NFS30	1	NZ5		SO		D

= NFS301NZ5OD

BOX 1	BOX 2	BOX 3			BOX 4
Filter Series	Number of Elements	Element Part Number			Seal Material
NFS30	1	N Length	NN Length		Omit = Buna N V = Viton® W = Buna N
		N3	NN3	= 3 μ E media (cellulose)	
		N10	NN10	= 10 μ E media (cellulose)	
		N25	NN25	= 25 μ E media (cellulose)	
		NZ1	NNZ1	= 1 μ Excellement® Z media (synthetic)	
		NZ3	NNZ3	= 3 μ Excellement Z media (synthetic)	
		NZ5	NNZ5	= 5 μ Excellement Z media (synthetic)	
		NZ10	NNZ10	= 10 μ Excellement Z media (synthetic)	
		NZ25	NNZ25	= 25 μ Excellement Z media (synthetic)	
		NM10		= 10 μ M media (reusable metal)	
		NM60		= 60 μ M media (reusable metal)	

BOX 5	BOX 6	BOX 7	
Porting	Options	Dirt Alarm® Options	
SO = SAE-12 PO = ¾" NPTF FO = 1" SAE 4-bolt flange Code 61 O = Manifold mounting	Omit = None X = Blocked bypass		Omit = None
		Visual	D = Pointer D5 = Visual pop-up
		Visual with Thermal Lockout	D8 = Visual w/ thermal lockout
		Electrical	MS5 = Electrical w/ 12 in. 18 gauge 4-conductor cable MS5LC = Low current MS5 MS10 = Electrical w/ DIN connector (male end only) MS10LC = Low current MS10 MS11 = Electrical w/ 12 ft. 4-conductor wire MS12 = Electrical w/ 5 pin Brad Harrison connector (male end only) MS12LC = Low current MS12 MS15DC = Electrical, direct current normally open, for DC use only MS15DCNC = Electrical, direct current normally closed, for DC use only MS16 = Electrical w/ weather-packed sealed connector MS16LC = Low current MS16 MS17LC = Electrical w/ 4 pin Brad Harrison male connector
		Electrical with Thermal Lockout	MS5T = MS5 (see above) w/ thermal lockout MS5LCT = Low current MS5T MS10T = MS10 (see above) w/ thermal lockout MS10LCT = Low current MS10T MS12T = MS12 (see above) w/ thermal lockout MS12LCT = Low current MS12T MS16T = MS16 (see above) w/ thermal lockout MS16LCT = Low current MS16T MS17LCT = Low current MS17T
		Electrical Visual	MS2 = Cam operated switch w/ 10" pigtail connection MS13 = Supplied w/ threaded connector & light MS14 = Supplied w/ 5 pin Brad Harrison connector & light (male end)
		Electrical Visual with Thermal Lockout	MS13DCT = MS13 (see above), direct current, w/ thermal lockout MS13DCLCT = Low current MS13DCT MS14DCT = MS14 (see above), direct current, w/ thermal lockout MS14DCLCT = Low current MS14DCT

NOTES:

- Box 3. Replacement element part numbers are identical to contents of Boxes 3 and 4.
- Box 4. E media (cellulose) elements are only available with Buna N seals. For options V and W, all aluminum parts are anodized. Viton is a registered trademark of DuPont Dow Elastomers.
- Box 5. For option O, O-rings included; fastening hardware not included.
- Box 7. For options SO, PO, and FO, available dirt alarms are D and MS2 only.