

## Introducing the SCHROEDER D-AB-4 DESICCANT AIR BREATHER

Schroeder Industries has expanded its line of disposable desiccant air breathers to include the D-AB-4.

### SCHROEDER D-AB-4 ADVANTAGES

- 2µm absolute solid particle filtration
- 35 CFM rated air flow with marginal pressure drop
- Anti-static features to protect against fire ignition
- High water absorption capacity (up to 15oz)
- Long operating life and low maintenance costs
- Environmentally safe disposable silica gel
- Compatibility with a variety of applications

### APPLICATIONS

- New and Retrofit Applications
- Hydraulic Reservoirs
- Gear Boxes
- Storage Tanks

### D-AB-4 MECHANICS AND SYSTEM PROTECTION

The Schroeder D-AB-2 and D-AB-4 desiccant air breathers are designed to increase operational efficiency while reducing operating costs by protecting industrial systems from moisture and particle contaminants.

As fluid levels drop and pressure changes occur in a system, moist air is drawn through the Schroeder breather (as shown in the diagram below). Air passes through a 2-micron solid contaminant filter and a diffuser (which ensures maximum efficiency in the silica gel chamber). Water vapor in the air is absorbed by the silica gel before the dry air passes through a second 2-micron solid contaminant filter. The filtered air that enters the reservoir is void of moisture and abrasive contaminants such as salts and acids. This filtration system:

- Prevents rust and oxidation
- Minimizes component wear and maintenance
- Curtails freezing and additive depletion
- Diminishes fluid degradation and orifice blockage
- Extends oil filter and hydraulic system life

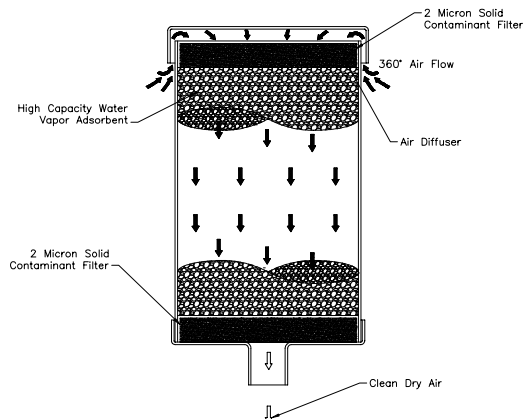

*SCHROEDER D-AB-2 AND D-AB-4 AIR BREATHERS*

### OPERATIONAL FEATURES

#### Bi-directional Air Flow

- As moist air flows through the breather's filtration system, it is cleaned of impurities and dried. Expelled air partially regenerates the silica gel and "backflushes" the particulate to prolong the life of the breather.

#### Durable Construction

- The Schroeder D-AB-4 is manufactured in the USA from rugged ABS plastic and impact-modified Plexiglas.

#### Water Vapor Absorbent

- Silica gel is chemically inert, non-toxic, non-deliquescent and non-corrosive. Its internal structure of interconnected microscopic pores absorbs up to 40% of its weight.

#### Color Indicator

- As the gold silica gel absorbs water, it turns green to indicate that it has reached its functional capacity and that replacement of the breather is required.

#### Dual Anti-static Filter System

- The solid contaminant filters are designed to reduce the potential for explosion in dusty environments.

#### Safety Sealed

- To ensure a long shelf life and premium operating performance, each Schroeder D-AB-4 breather is individually sealed and vacuum packed to protect it from moisture before it is placed in service. All seals are easily removable without the use of tools or sharp instruments.



## UNIT SELECTION GUIDE

Model	Diameter (A)	Height (B)	Unit Weight	Silica Gel Weight	Max H2O Capacity
D-AB-2	3.25in/8.3cm	4.3in/10.9cm	0.75lb/0.3kg	0.4lb/6.4oz	0.18lb/0.09ltr
D-AB-4	5in/12.7cm	9.25in/23.5cm	3.3lb/1.5kg	2.4lb/38.4oz	0.9lb/0.5ltr

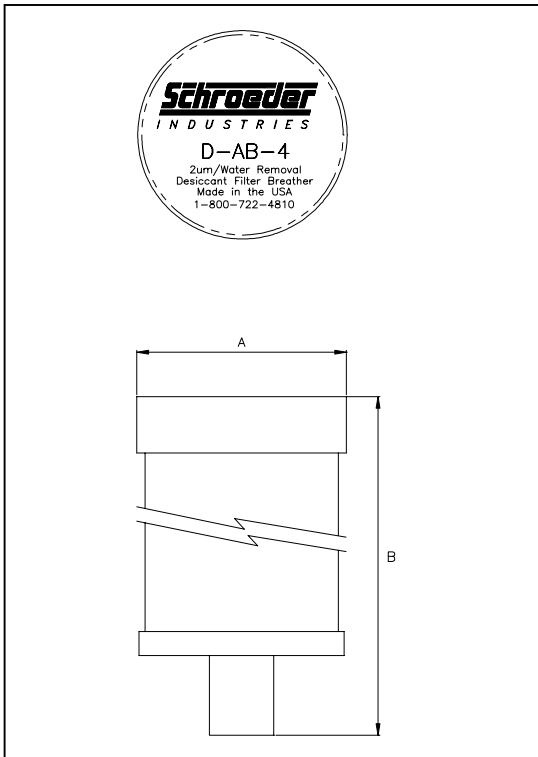

## FLOW RATE VS PRESSURE DROP

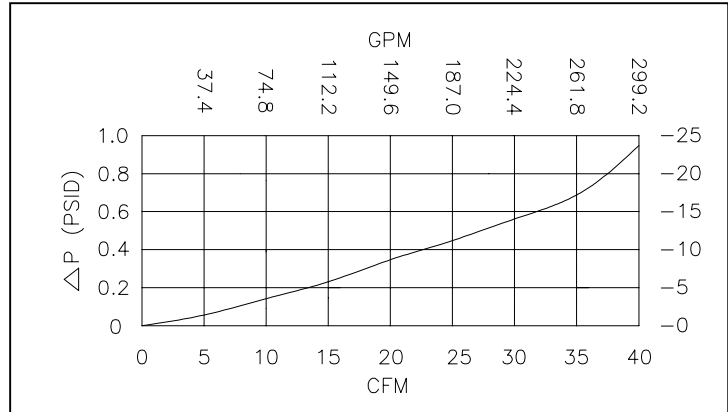

## COLOR INDICATOR



## ADAPTER SELECTION GUIDE

